

## Rebuild procedures for JSK 37 series fifth wheels

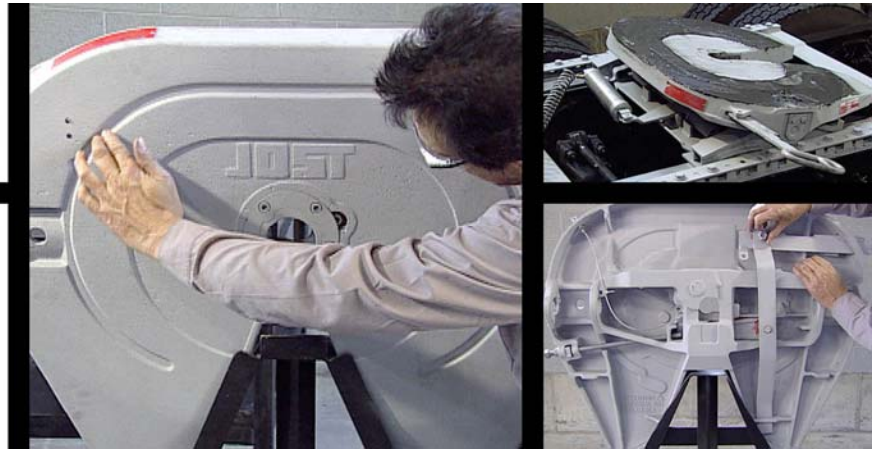

### TROUBLESHOOTING HINTS

Problem	Cause	Correction
Hard to couple	Coupling too fast	Pick up the trailer with the fifth wheel. <b>STOP</b> . Then, continue backing until coupled.
	Trailer is too high.	Lower the trailer. The fifth wheel <b>MUST</b> pick up the trailer.
	Lock is already closed.	Pull the release handle open.
	Bent release handle.	Inspect, and/or pull the release handle. If it is bent, replace it.
	Damaged lock, or debris interfering with lock operation.	Have an assistant pull the release handle out, while attempting to swing the lock. Lock should swing freely. Then lock and unlock using a lock tester.
	Using lube plate with wrong length kingpin.	Inspect kingpin length using a Jost Kingpin Gage.
	Bent kingpin or damaged trailer bolster plate.	Check the kingpin with a Jost kingpin gage. Inspect and repair bolster plate as required.
	Release arm or release handle pivot nuts too tight, or double coil spring not installed.	Review the rebuild procedures, and repair as required.
Hard to uncouple	Lock is closed, release handle was never pulled.	Pull the handle out, rotate it forward and rest it on the notch provided.
	Can't pull release handle. The tractor may be putting pressure on the lock.	Set the trailer brakes, back into trailer with the tractor, and then set tractor brakes. Now pull the release handle.
	Can't pull release handle. Lock is adjusted too tight.	Review the lock adjustment procedure (page 7) for lock that is adjusted too tight.
	Can't pull release handle. Release handle and release arm pivots are too tight.	Review the rebuild procedure (page 6) and repair as required.
	Bent kingpin or damaged trailer bolster plate.	Check the kingpin with a Jost kingpin gage. Inspect and repair bolster plate as required.
	Release handle notch damaged or worn.	Check the notch on the release handle, replace as required.
	Release handle slot in casting is damaged or worn.	Inspect the release handle slot in casting and replace or repair as required.

**Important:** Before attempting to rebuild your fifth wheel, review the troubleshooting hints in this manual. You may find that rebuilding is not necessary.

Rebuilding should be considered when all of the available adjustment is used and the lock tester moves fore and aft 1/8" when properly locked.

## INSPECTION

### 1. EXAMINE TOPPLATE SURFACE

If the topplate surface is worn down to the grease groove at any point, the top plate should not be rebuilt it should be discarded. (see figure 1)



FIGURE 1

### 2. MEASURE TWO PARTS

Measure the cushion ring and the lock jaw, the fifth wheel should be rebuilt if the dimension shown is worn to .69" (17.5mm). (see figures 2 and 3)



FIGURE 2



FIGURE 3

---

# DISSASSEMBLY

---

## 1. CLOSE THE LOCKING MECHANISM.

To do this, pull the release handle out while swinging the lock jaw into the closed position (see figure 4). Now let the release handle slide slowly to the closed position.

## 2. REMOVE DOUBLE COIL SPRING.

Be sure to remove the spring from casting lug first, using a suitable tool.

## 3. REMOVE THE RELEASE HANDLE.

The release may need to be pulled slightly to the opened position. Then, remove the cotter pin and castellated nut on the release handle and remove the release handle.

## 4. REMOVE THE RELEASE ARM AND LOCK BAR.

Remove the cotter pin and castellated nut on the lock bar and remove release arm and lock bar.

## 5. REMOVE THE CIRCLE RING.

Remove the circle ring securing the lock jaw spring and allow extension spring to relax. (see figure 5).

## 6. REMOVE THE LUBRICATION LINE.

Loosen the jam nut attaching the lubrication line to the casting skirt and remove the line attached to the lock jaw. Then, slide the jam nut off the end of the line. Slide the lubrication line through the casting skirt.



FIGURE 4



FIGURE 5

---

**Important:** At this point, be sure to examine the structural ribs of the top plate casting for cracks.

If cracks are present, the top plate casting must be discarded.

---

---

## DISSASSEMBLY con't

---

### 7. REMOVE THE CUSHION RING AND RETAINER.

Turn the topplate face up. Remove the (4) cushion ring bolts using a 5/16" Allen wrench (see figure 6). Then, pry out the cushion ring retainer from the casting and remove the cushion ring (see figure 7).



FIGURE 6



FIGURE 7

### 8. REMOVE THE LOCK JAW.

Thread one of the cushion ring bolts into the lock jaw pivot pin and lift the pin from the casting. Now, remove the lock jaw reaching under the topplate and sliding the lock out of the casting (see figure 8).



FIGURE 8

### 9. REMOVE THE ADJUSTMENT SCREW.

Loosen the jam nut and remove the adjustment screw and guide piece.

### 10. REMOVE THE RELEASE HANDLE LEAF SPRING.

Remove the (2) hex head screws and lock washers that secure the leaf spring.

---

# RE-ASSEMBLY

---

## 1. INSTALL THE RELEASE HANDLE LEAF SPRING.

Be sure to install both screws and lock washers when attaching the leaf spring and tighten securely.

## 2. INSTALL THE ADJUSTMENT SCREW.

Place the adjustment screw guide piece in the space provided with the threaded hole up (see figure 9). Then, make sure the jam nut is threaded onto the adjustment screw and thread it through the guide piece.



FIGURE 9

## 3. INSTALL THE LOCK JAW.

Be sure to install the lock jaw in the same orientation it was removed (see figure 8). Lubricate the lock jaw pivot pin and secure the lock jaw by inserting it into the casting through the slot in the lock jaw.

## 4. INSTALL THE CUSHION RING AND RETAINER.

Make sure to carefully line up the bolt holes, and then install (4) new cushion ring bolts. Be sure to tighten and torque bolts to 45 ft-lbs (see figure 10).



FIGURE 10

## 5. INSTALL THE LUBRICATION LINE.

Feed the lubrication line through the casting skirt and through the jam nut and thread into the lock jaw. Tighten finger tight and then using a wrench tighten securely. Tighten the nut on the casting skirt and now, attach the lube line to the rib using a wire tie.

## 6. INSTALL THE CIRCLE RING.

Extend the extension spring, place the end of the eye bolt through the casting rib and secure with the circle ring (see figure 5).

---

## RE-ASSEMBLY con't

---

### 7. INSTALL THE LOCK BAR.

Lubricate the lock bar pivot bolt and slide it through the lock bar. Lubricate the edges of the lock bar (see figure 11). Insert the lock bar into the slot in the casting.

### 8. INSTALL THE RELEASE HANDLE.

Slide the release handle through the casting, and then slide the release handle bolt up through the bottom and lubricate both pivots thoroughly (see figure 12).



FIGURE 11



FIGURE 12

### 9. INSTALL THE RELEASE ARM.

Slide the chamfered end of the release arm through the slot provided in the ramp of the casting (see figure 13). Swing the release arm down over the lock bar bolt and release handle bolt.

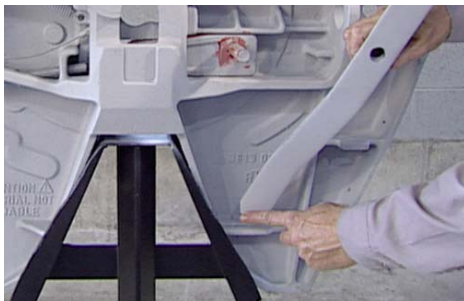

FIGURE 13



FIGURE 14

Install the flat washer and castellated nut on the release handle, tighten finger tight, then back off  $\frac{1}{2}$  to 1 full turn and install a cotter pin in this position.

Install the flat washer and castellated nut on the lock bar bolt. Tighten finger tight, then back off until you can just insert the cotter pin. Install the cotter pin.

**IMPORTANT: Make sure that both cotter pins are adequately secured.**

# RE-ASSEMBLY con't

## 10. INSTALL DOUBLE COIL SPRING.

Swing the lock jaw into the closed position then push the release handle closed. Install the double coil spring up through the tab on the release handle then, using a suitable tool, secure the opposite end onto the lug.

**IMPORTANT: Exercise extreme caution while doing this.**

## 11. INSTALL TOPPLATE.

Lower the topplate onto the mounting bracket using a suitable lifting device. Install the bracket pins, tab washers and mounting bolts. Securely tighten the mounting bolts, then bend the locking tabs over each bolt (see figure below).

**Assembly Tip:** Before putting the topplate back on the mounting bracket, liberally grease the top of the pivot collars to help hold them in place.

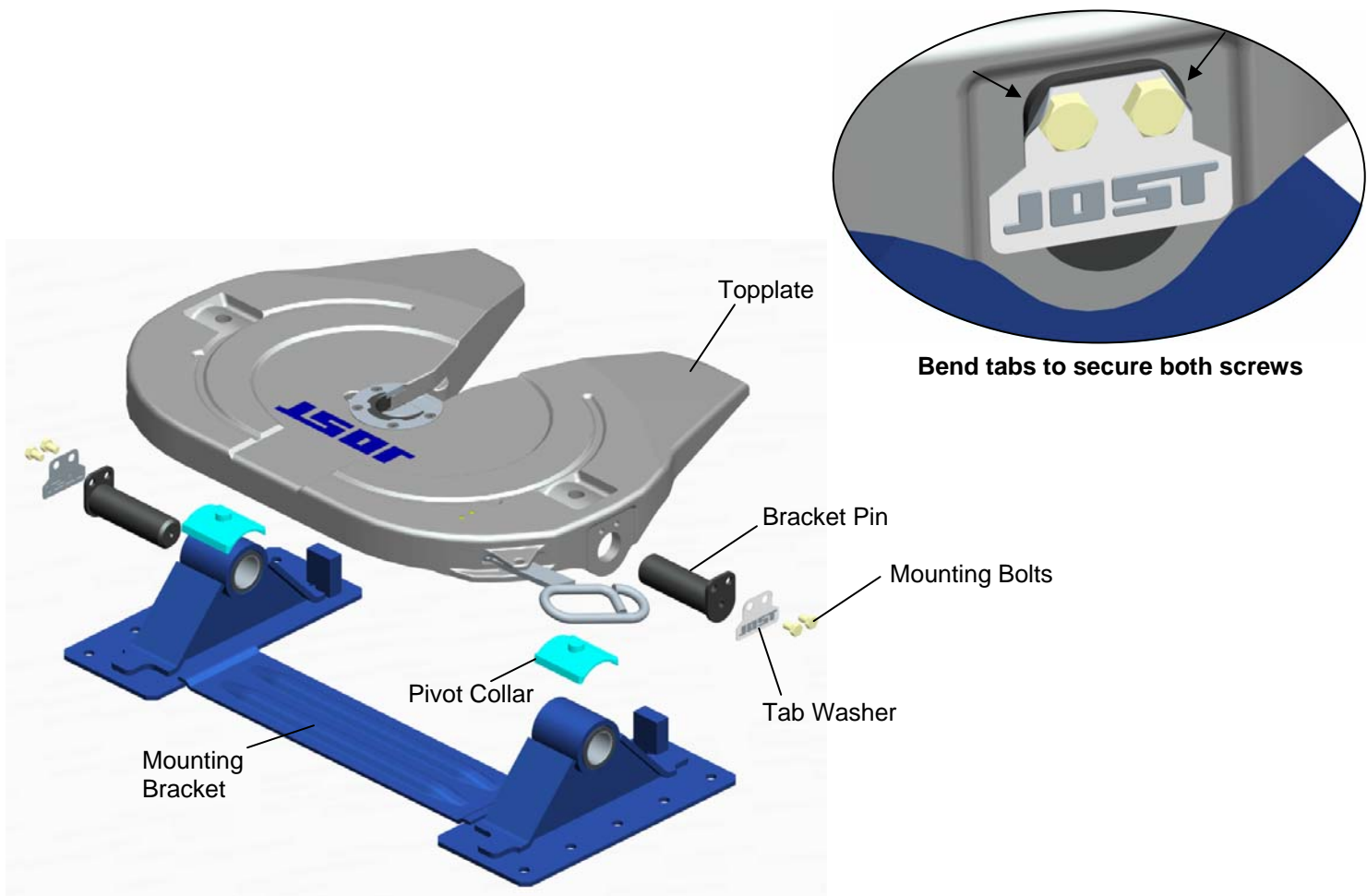

# LOCK ADJUSTMENT

**CHECK ADJUSTMENT** - Lock and unlock several times using a lock tester.

- A. **THE LOCK IS PROPERLY ADJUSTED IF:** The wheel locks and unlocks easily each time and the lock tester rotates freely.
- B. **THE LOCK IS TOO LOOSE IF:** You feel fore-aft play when pulling and pushing on the lock tester handle (see figure 15)
- C. **THE LOCK IS TOO TIGHT IF:** The lock tester does not rotate freely when attempting to rotate it in the lock. (See figure 16)



Look for movement of kingpin in lock

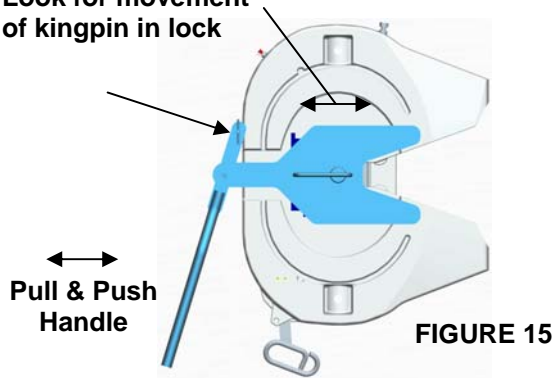

Disengage Hook

Rotate Lock Tester

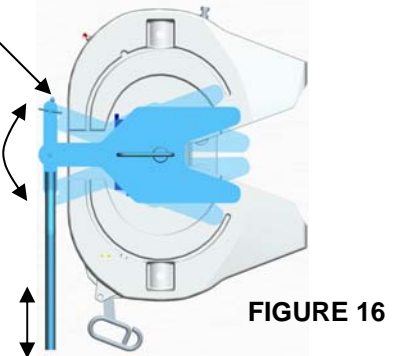

## **CORRECT IMPROPER ADJUSTMENT**

- A. **IF IT IS TOO TIGHT:** loosen the jam nut, turn the adjustment screw clockwise one full turn and reset the jam nut. Then, lock and unlock several times, repeat if necessary.
- B. **IF IT IS TOO LOOSE:** loosen the jam nut, turn the adjustment screw counterclockwise one full turn and reset the jam nut. Then, lock and unlock several times, repeat if necessary.

TURN ADJUSTMENT SCREW  
CLOCKWISE COUNTER CLOCKWISE



IF TOO TIGHT



IF TOO LOOSE

For complete parts list and rebuild kit order numbers see the maintenance procedures that came with your fifth wheel.

or

Contact our sales department at:

**800-253-5105**