

**Cushion and Lock Jaw Rebuild Kit** (For L.H. only)  
**Part #SK 73221-50Z**

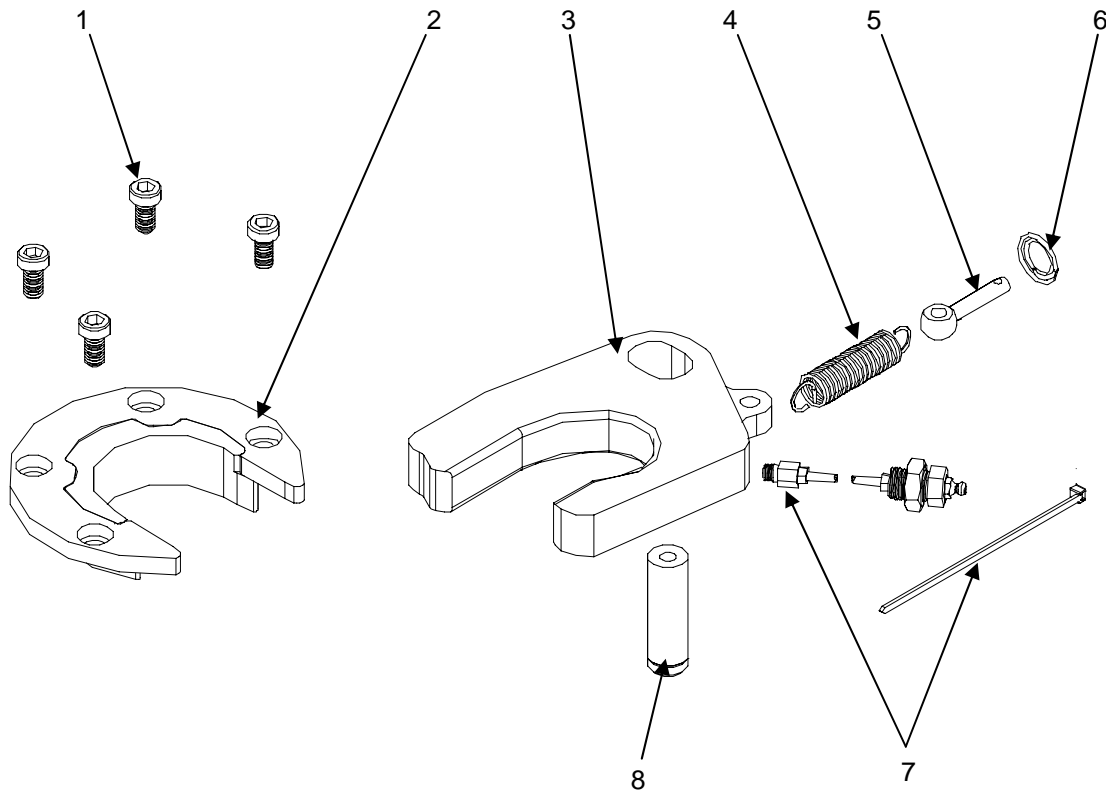

Item	Description	Part No.	Item	Description	Part No.
1	Cushion ring bolt	SK 73121-55	6	Ring	SK 2106-70
2	Cushion Ring Assembly	SK 79002-00	7	Lubricating kit	SK 3108-02
3	Lock jaw	SK 1489LZ	8	Lock jaw pivot pin	SK 72106-67
4	Lock jaw spring	SK 847			
5	Eye bolt	SK 2106-69			

# DISASSEMBLY

## 1. CLOSE THE LOCKING MECHANISM.

Pull the release handle out and swing the lock jaw into the closed position (see figure 1a).



Now let the release handle slide slowly to the closed position (see figure 1b).

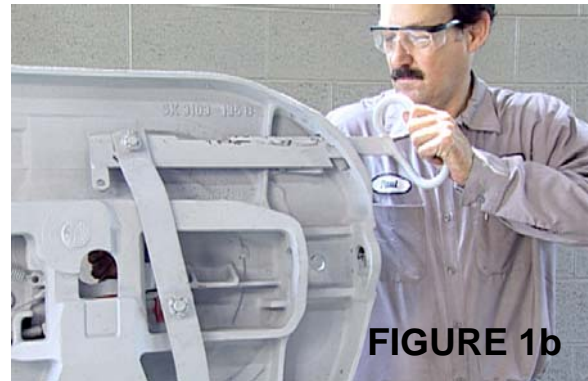

## 2. REMOVE DOUBLE COIL SPRING.

Using a suitable tool remove the spring from casting lug first (see figure 2).

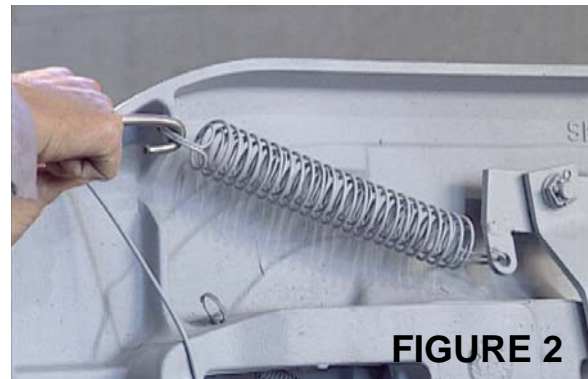

## 3. OPEN THE LOCKING MECHANISM.

Slide the release handle to the opened position (see figure 3).



---

## DISASSEMBLY con't

---

### 4. REMOVE THE CIRCLE RING.

Remove the circle ring securing the lock jaw spring (see figure 4a) and allow extension spring to relax (see figure 4b).

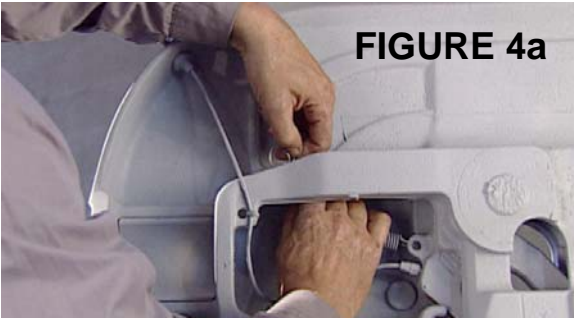

### 5. REMOVE THE CUSHION RING AND RETAINER.

Remove the (4) cushion ring bolts using a 5/16" Allen wrench (see figure 5a). Then, pry out the cushion ring retainer from the casting and remove the cushion ring (see figure 5b).

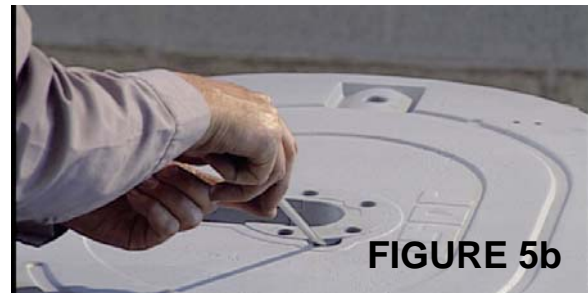

### 6. REMOVE THE LOCK JAW PIVOT PIN.

Thread one of the cushion ring bolts into the lock jaw pivot pin (see figure 6a) and lift the pin from the casting (see figure 6b).



---

## DISASSEMBLY con't

---

### 7. REMOVE THE LOCK JAW.

Remove the lock jaw by reaching under the top plate and sliding the lock out of the casting (see figure 7).

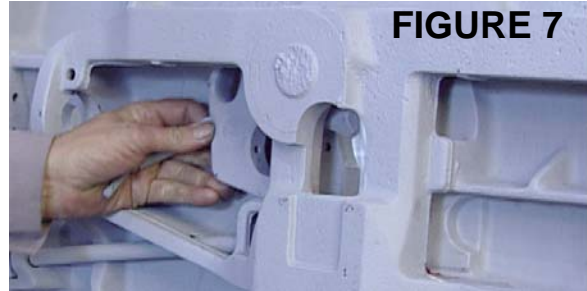

### 8. REMOVE THE LUBRICATION LINE.

Remove the lubrication line from the lock jaw.

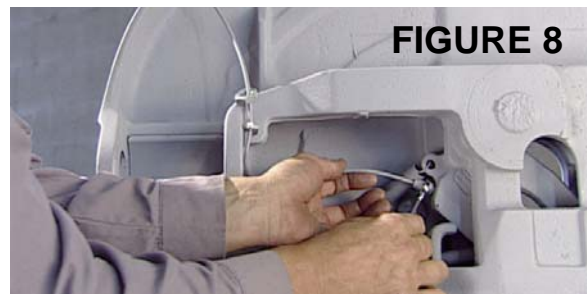

---

## RE-ASSEMBLY

---

### 1. INSTALL THE LUBRICATION LINE.

Re-attach the lubrication line to the lock jaw.



### 2. INSTALL THE LOCK JAW.

Be sure to install the lock jaw in the same orientation it was removed (see figure 10).



### 3. INSTALL THE CIRCLE RING.

Place the end of the eye bolt through the casting rib and secure with the circle ring (see figure 11).

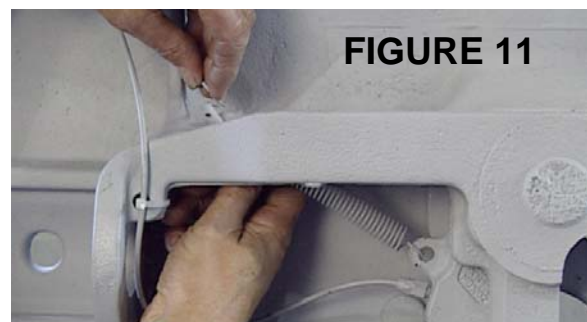

## RE-ASSEMBLY con't

### 4. INSTALL THE LOCK JAW PIVOT PIN.

Lubricate the lock jaw pivot pin and secure the lock jaw by inserting it into the casting through the slot in the lock jaw (see figure 12).

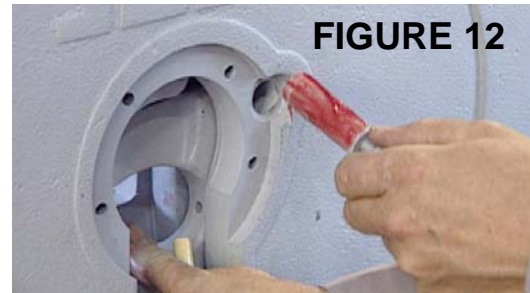

### 5. INSTALL THE CUSHION RING AND RETAINER.

Carefully line up the bolt holes (see figure 13a), and then install (4) new cushion ring bolts. Tighten and torque bolts to 45 ft-lbs (see figure 13b).

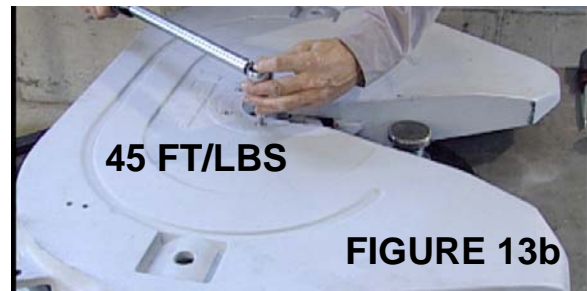

### 6. CLOSE THE LOCKING MECHANISM.

Pull the release handle out and swing the lock jaw into the closed position (see figure 14a).



Now slide the release handle into the closed position (see figure 14b).



### 7. ATTACH DOUBLE COIL SPRING.

Using a suitable tool attach the spring as shown (see figure 2).

# RE-ASSEMBLY con't

## 8. CHECK ADJUSTMENT - Lock and unlock several times using a lock tester.

- A. THE LOCK IS PROPERLY ADJUSTED IF: The wheel locks and unlocks easily each time and the lock tester rotates freely.
- B. THE LOCK IS TOO LOOSE IF: You feel fore-aft play when pulling and pushing on the lock tester handle (see figure 4)
- C. THE LOCK IS TOO TIGHT IF: The lock tester does not rotate freely when attempting to rotate it in the lock. (See figure 5)

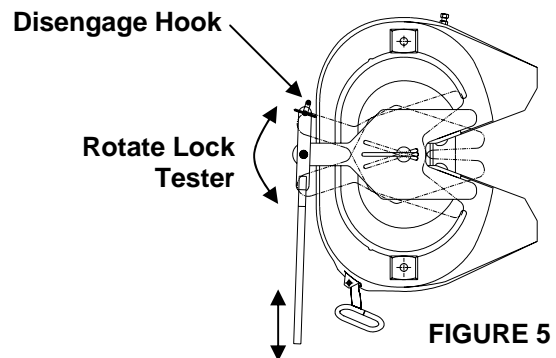
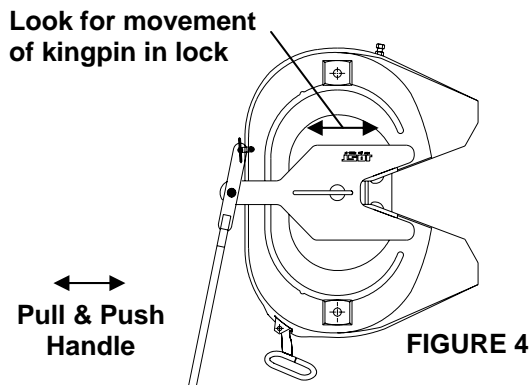

## 9. CORRECT IMPROPER ADJUSTMENT

- A. IF IT IS TOO TIGHT: loosen the jam nut, turn the adjustment screw clockwise one full turn and reset the jam nut. Then, lock and unlock several times, repeat if necessary.
- B. IF IT IS TOO LOOSE: loosen the jam nut, turn the adjustment screw counterclockwise one full turn and reset the jam nut. Then, lock and unlock several times, repeat if necessary.

