

**Jost International announces the availability of an
Air Release Fifth Wheel.**

The main feature of the Jost design is the Automatic Engaging Secondary Lock.

Features	Benefit
1. Automatic Engaging Secondary Lock	Keeps mechanism locked
2. Visual Lock Indicator	Visual confirmation of proper locking
3. Simple Mechanism	Reliable coupling
4. Full Size Release Handle	Easy to uncouple as a manual release

Fifth Wheel Uncoupling Operation

1. Fifth Wheel Closed and Secure

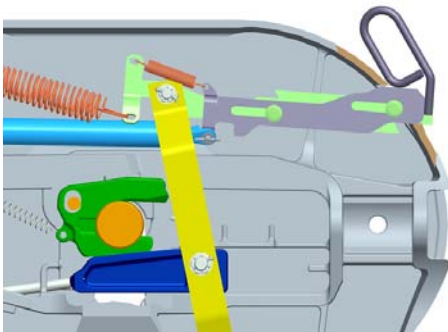

2. Cylinder Energized

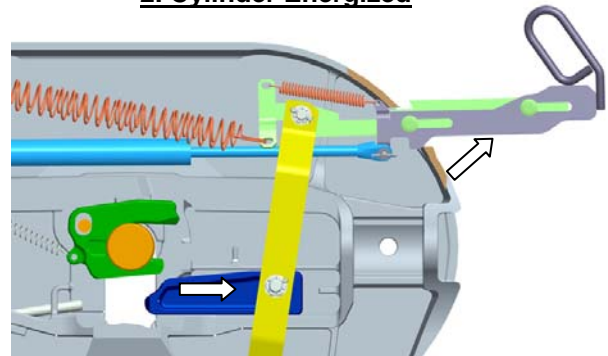

**3. Air Pressure removed,
Handle held on the notch**

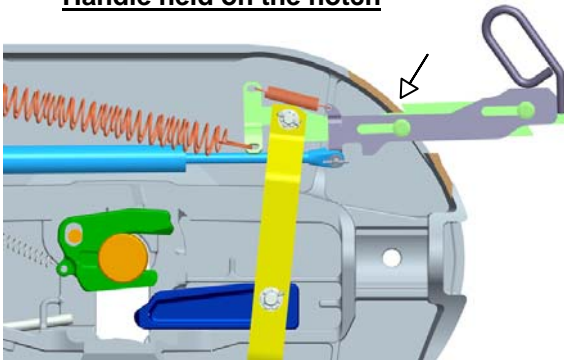

**4. Kingpin contacts the Lock Bar re-setting
the Fifth Wheel for coupling**

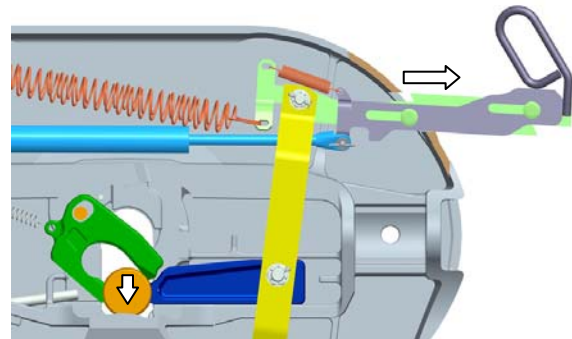

5. Mechanism held open by Lock Jaw against the Lock Bar

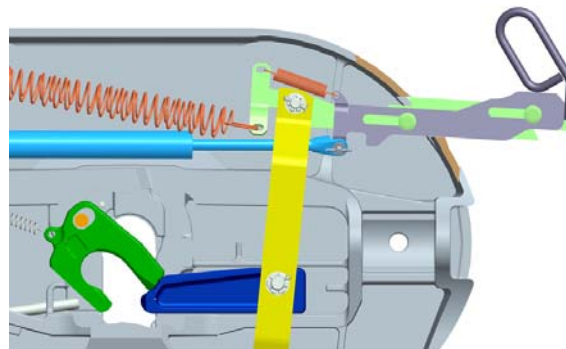

Fifth Wheel Coupling Operation

1. Kingpin enters into locking mechanism

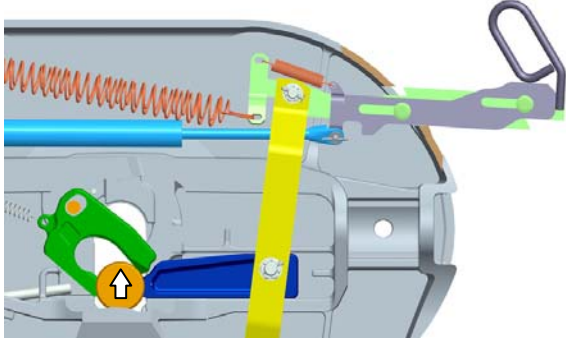

2. Kingpin swings Lock Jaw Closed and the Lock Bar slides in to secure it.

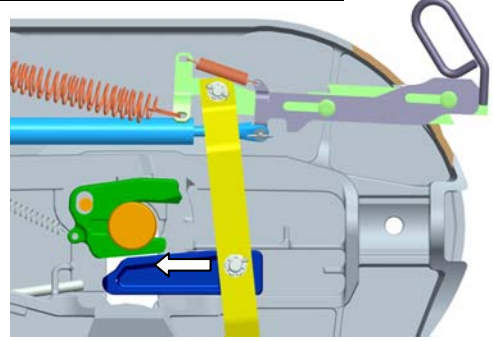

3. Release Handle moves into the closed position

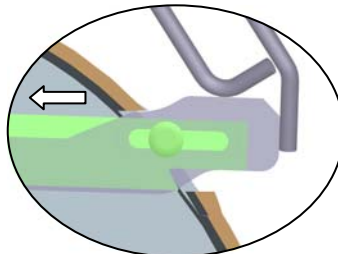
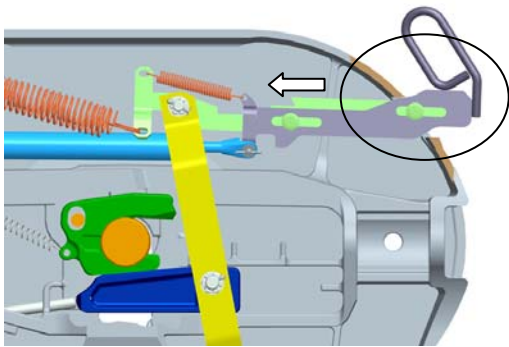

3A. Handle portion (green) continues to close

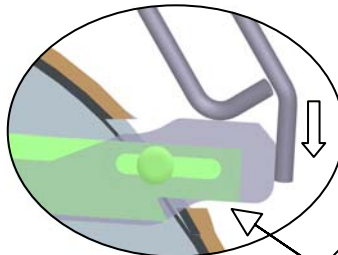

3B. Primary Lock engages

4. Retractable Handle moves into the close position

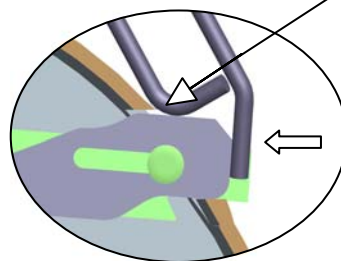
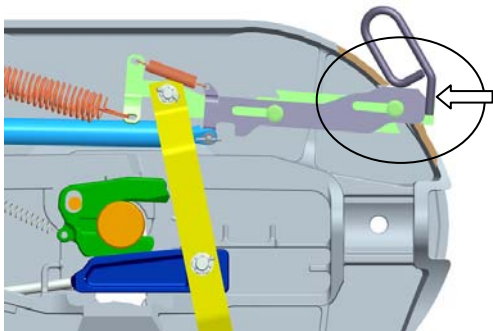

4A. Retractable Handle portion (purple) provides the secondary lock

To Order: Select the "A" as the Topplate Release Type in the topplate model number as shown below

e.g. JSK37US"A"

Fifth Wheel Product
JSK

Topplate
37U

Topplate Surface
—

Topplate Release Type
—

Standard Lube Surface – S
With Low Lube Plates – W
Auto Lube (4 holes) – A

A - Air Release
L - Standard Handle L.H. Release
R - Standard Handle R.H. Release
B - Retractable Handle L.H. Release