

The reasons are simple.



INSTALLATION INSTRUCTIONS

For Air Release Manifold Kit

AIR RELEASE MANIFOLD ASSEMBLY KIT

Part #SK 75002-05

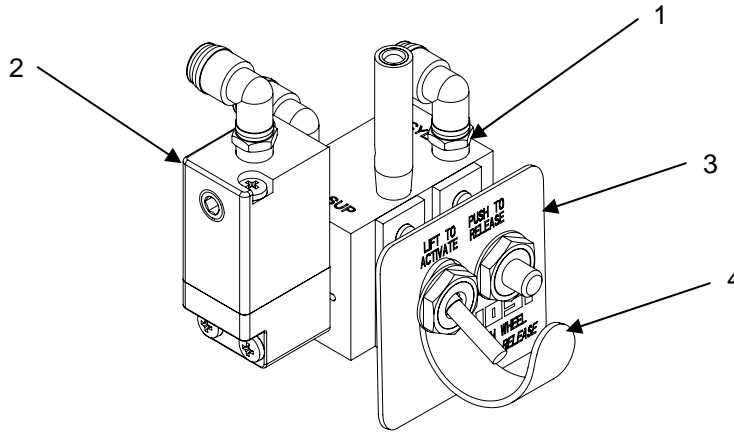

Item	Description	Part No.
1	Air Release Manifold Valve	SK 75002-08
2	Air Release Inversion Valve	SK 75002-10
3	Cab Control Plate	SK 75002-07
4	Finger Guard	SK 75002-13

COMPONENTS

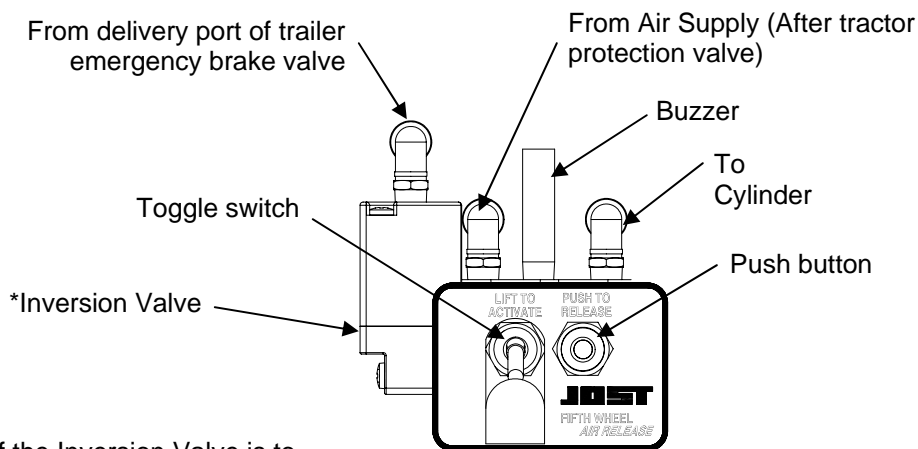

FIGURE 1

* The purpose of the Inversion Valve is to allow air to go to the release cylinder only if the trailer emergency brakes are set.

INSTALLATION PROCEDURE



WARNING

THE AIR RELEASE SYSTEM MUST BE PROPERLY INTERLOCKED WITH THE TRACTOR/TRAILER BRAKE SYSTEM. IMPROPER INSTALLATION OF AIR LINES AND/OR AIR MANIFOLD ASSEMBLY COULD CAUSE UNINTENTIONAL UNCOUPLING AS A RESULT OF ACCIDENTAL ACTIVATION. THE CONSEQUENCES COULD BE SERIOUS BODILY INJURY, DEATH AND/OR SIGNIFICANT PROPERTY DAMAGE.

A. INSTALL THE VALVE.

1. Install a tee in the line from the delivery port of the trailer emergency brake valve. Connect a line from the tee to the port on the inversion valve (see figure 1).
2. Connect an air source from the tractor (after the tractor protection valve) to the port labeled "From Air Supply" on the air release manifold (see figure 1).
3. Connect a line from the port labeled "To Cylinder" on the air release manifold (see figure 1) to the port on the air release cylinder under the fifth wheel topplate (see figure 2).

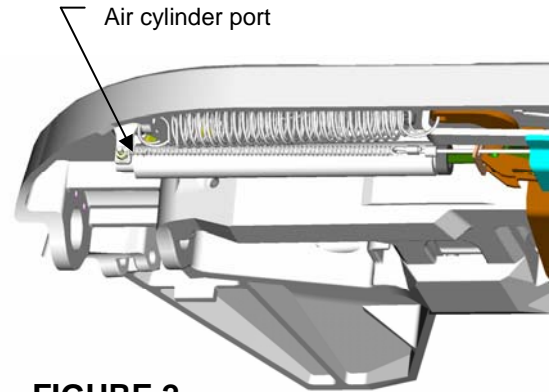

FIGURE 2

B. CHECK FOR PROPER OPERATION.

1. With the trailer brakes off:
Move the toggle switch to the activated position (see figures 3 & 4), depress the push button. The Buzzer should NOT sound and the air cylinder should NOT extend.
2. With the trailer brakes on:
Move the toggle switch to the activated position (see figures 3 & 4), depress the push button. The Buzzer should sound and the air cylinder should extend.
3. Couple and uncouple to several different trailers to check for proper operation as described in Jost Air Release Operating Instructions LT JSK37 USA-02 supplied with the Jost Air Release Fifth Wheel.

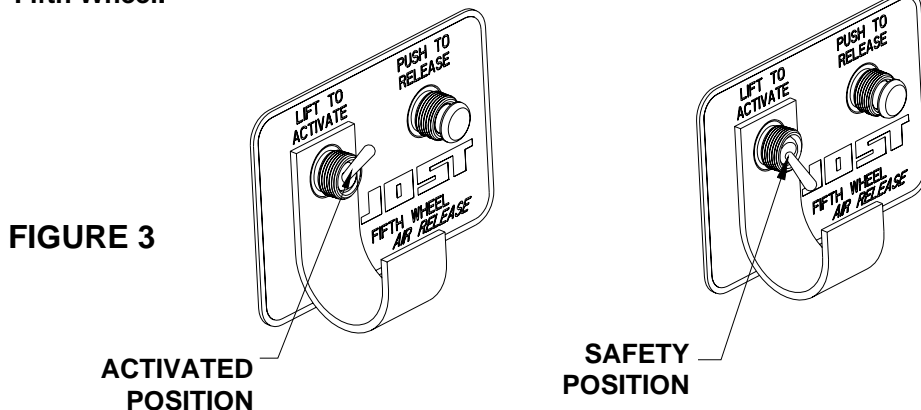

FIGURE 3

FIGURE 4