



- 1. FAILURE TO FOLLOW THESE INSTRUCTIONS COULD CAUSE A HAZARDOUS CONDITION!**
- 2. PERFORM ALL MAINTENANCE WITH TRACTOR UNCOUPLED FROM TRAILER.**
- 3. ALL PROCEDURES MUST BE PERFORMED BY QUALIFIED PERSONNEL.**

A. LUBRICATION (as required):

1. Lubricate the kingpin lock using a hand pump grease gun through the grease zerk provided on the skirt of the fifth wheel (see figure 1).
2. Apply a lithium-based grease with EP additive (extreme pressure) to the trailer contact surface of the fifth wheel.
3. Apply a light oil to all moving parts.
4. For sliding fifth wheels spray diesel fuel on slide path of the base plate.

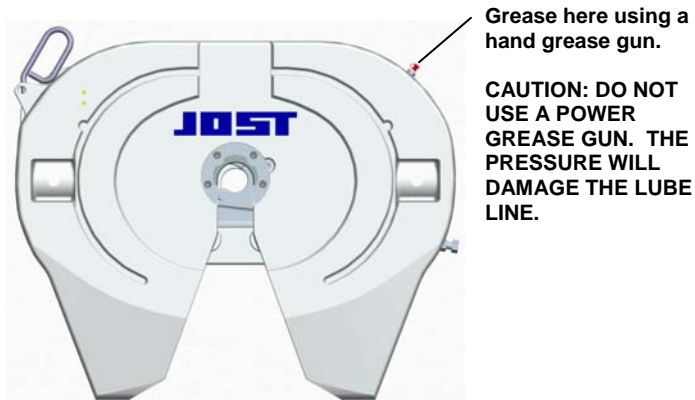

FIGURE 1

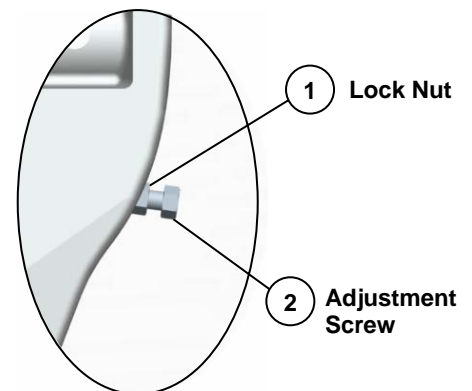
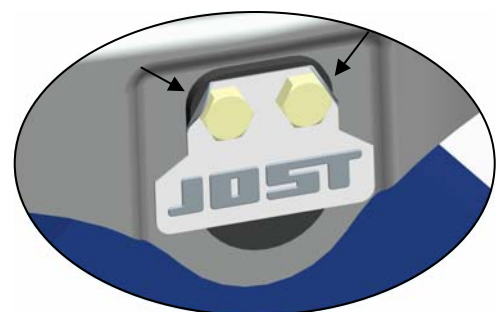

FIGURE 2

B. INSPECTIONS AND ADJUSTMENTS:

(Perform the following every 3 months or 30,000 miles)

1. Inspect the mounting – repair or replace any missing or damaged fasteners or broken components.
2. Inspect bracket pin bolts, make sure locking tabs are properly securing the bolts in place (see figure #3).
3. Inspect the fifth wheel for bent, worn or broken parts. Replace with genuine **JOST** parts.
4. Inspect the retractable handle – handle must freely extend and retract through the entire range available. Replace with a new retractable handle if damaged.



Locking tabs properly securing bolts

FIGURE 3

5. **Check adjustment** - Lock and unlock several times using a lock tester. Check that the locking mechanism functions properly (see operating procedures).

- a. **The lock is properly adjusted if:** The wheel locks and unlocks easily each time and the lock tester rotates freely.
- b. **The lock is too loose if:** You feel fore-aft play when pulling and pushing on the lock tester handle (see figure 4)
- c. **The lock is too tight if:** The lock tester does not rotate freely when attempting to rotate it in the lock. (See figure 5)

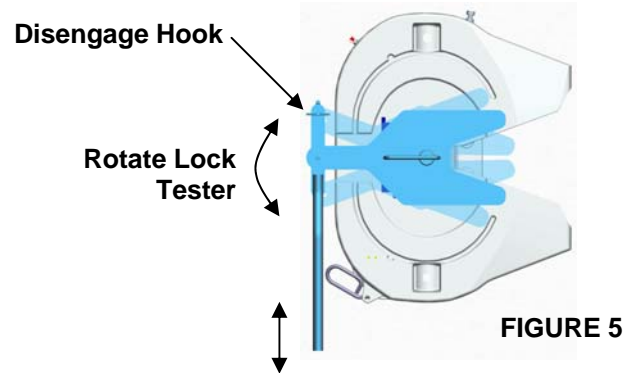
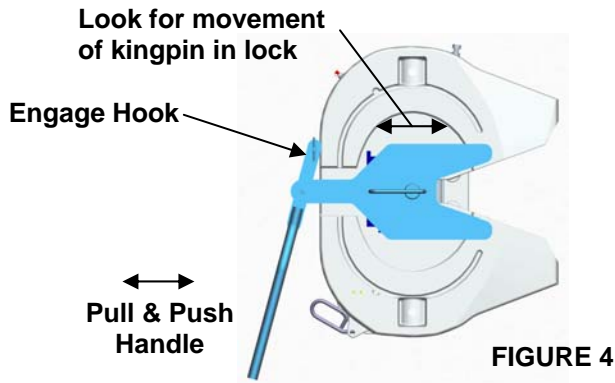

6. **Correct improper adjustment.**

- a. **IF IT IS TOO TIGHT:** loosen the jam nut (see figure 2 item 1), turn the adjustment screw (see figure 2 item 2) clockwise one full turn and reset the jam nut. Then, lock and unlock several times, repeat if necessary.
- b. **IF IT IS TOO LOOSE:** loosen the jam nut, turn the adjustment screw counterclockwise one full turn and reset the jam nut. Then, lock and unlock several times, repeat if necessary.

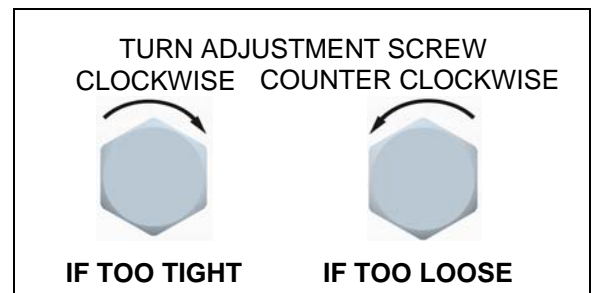



WARNING **DO NOT USE ANY FIFTH WHEEL THAT FAILS TO OPERATE PROPERLY!**

SLIDING FIFTH WHEEL MECHANISM **INSPECTION AND ADJUSTMENT**

A. Inspection

1. Inspect the bracket for any cracks or missing and damaged parts.
2. Inspect the locking plungers for full engagement.
3. Check the locking mechanism for proper operation.
 - a. If plungers won't release – check air cylinder or plunger adjustment.
 - b. If plungers are loose – check plunger adjustment or plunger springs for proper compression. Replace if required.

B. Adjustment

1. The outboard slider assembly requires no adjustment. If the plungers are loose inspect and replace locking mechanism parts as required.
2. The Inboard slider is adjustable for frame width as well as plunger engagement. For adjustment, refer to the Fifth Wheel Installation Instructions (Jost Publication LT SK37U-01).

PARTS LIST

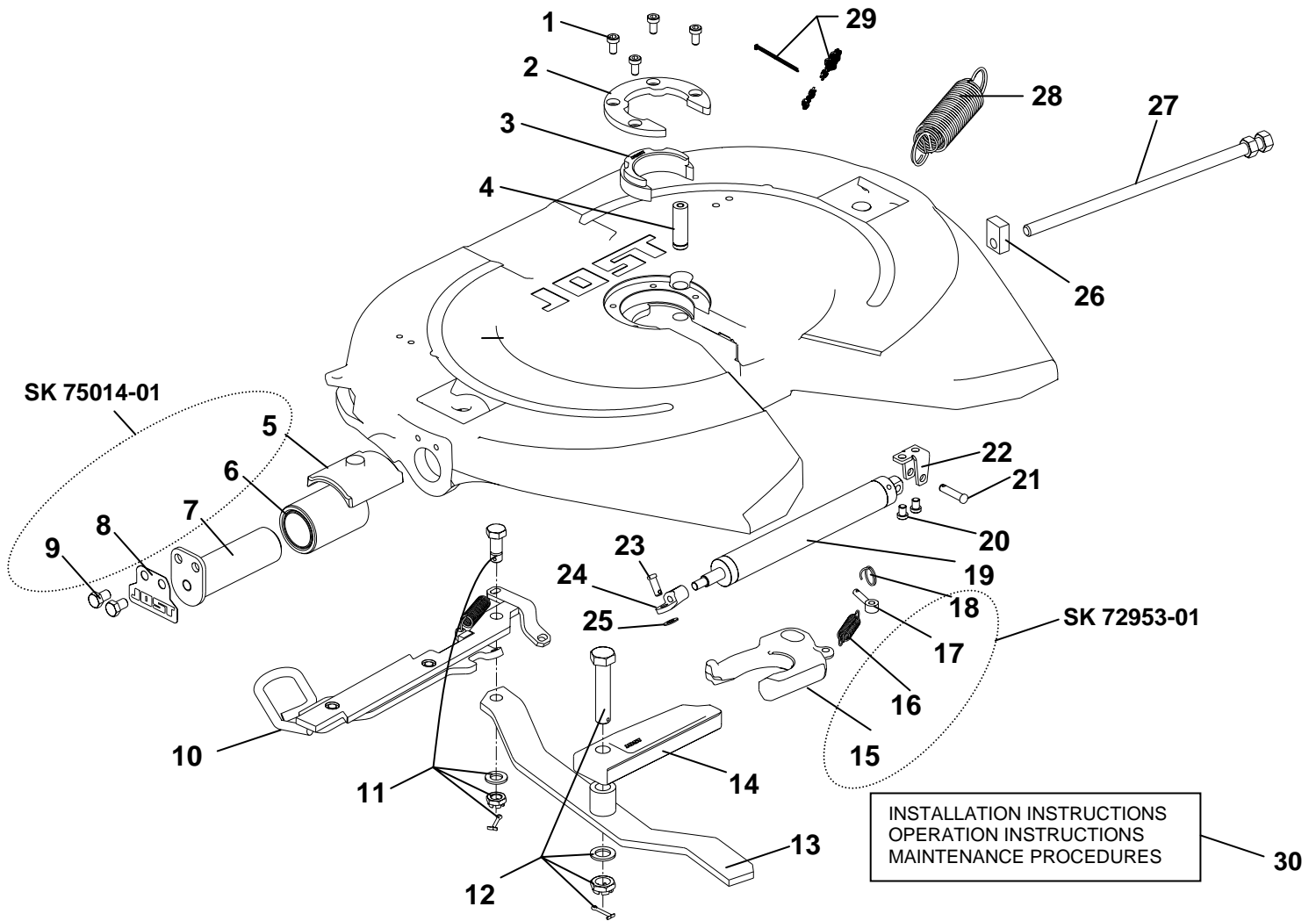

Item	Description	Part No.	Item	Description	Part No.
1	Cushion ring bolt	SK-73121-55	16	Lock jaw spring	SK-847
2	Retainer	SK-3105-93	17	Eye bolt	SK-2106-69
3	Cushion ring insert	SK-3105-92	18	Ring	SK-2106-70
4	Lock jaw pivot pin	SK-72106-67	19	Air cylinder	SK-79020-04
5	Collar	SK-3105-95	20	3/8-16 x 1/2 lg. Low head screw	SK-70209-00
6	Rubber Bushing	SK-2905-94	21	3/8 dia. Clevis pin (long)	SK-70105-00
7	Bracket pin	SK-79011-03	22	Cylinder mount	SK-79020-05
8	Tab washer	SK-73104-47	23	3/8 dia. Clevis pin (short)	SK-70105-01
9	1/2-13 x 3/4 lg. Hex bolt	SK-70202-15	24	Cylinder clevis	SK-79020-06
10	Retractable handle w/spring	SK-75016-04	25	Flat washer	SK-70302-01
11	Pivot bolt assembly	SK-71513	26	Guide piece	SK-73205-07
12	Locking bar bolt assembly	SK-73221-01	27	Adjusting screw with hex nut	SK-3105-151
13	LH Lever w/chamfer	SK-3105-140	28	Double tension spring	SK-3105-20
14	Locking bar	SK-3205-06	29	Lubricating kit	SK-3108-02
15	LH Lock jaw	SK-1489LZ	30	Info pack	SK-75020-09