

JOST Replacement for competitive Models 5000, 5092, 6000 & 7000 except when using the 7" high LWS slider.



**FAILURE TO FOLLOW THESE INSTRUCTIONS
COULD CAUSE A HAZARDOUS CONDITION!**



**INSTALLING YOUR JSK37F TOPPLATE WILL RAISE
THE INSTALLED FIFTH WHEEL HEIGHT BY 5/16".**

A. REMOVE OLD TOPPLATE:

1. Remove the excess grease from the topplate as required.
2. Remove the bracket pins and discard.
3. Using a suitable lifting device, lift the old topplate from the mounting bracket and discard.
4. Inspect the bracket bushings. Remove and replace if distorted or damaged.

B. INSTALL **JOST** MODEL JSK 37F TOPPLATE:

1. Remove the 1/2-13 hex head cap screws (figure 1 item 1) and locking tabs (item 2).
2. Remove the bracket pins (item 3).
3. Inspect the top of the bracket cap and grind off any high or rough spots (see figure 2).
4. Identify proper collar (item 4). See LT SK37F-05 for identification, and then apply grease to the top surface of the collars as shown in figure 4.
5. Install collars (item 4) into the pivot pockets of the fifth wheel topplate.

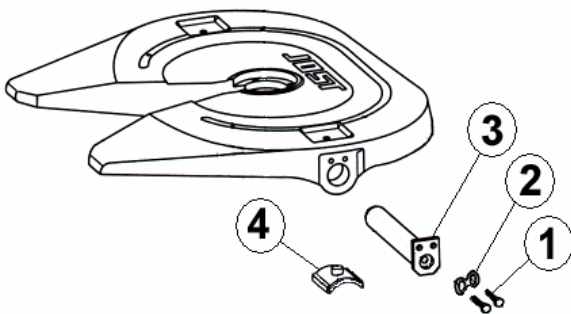

FIGURE 1

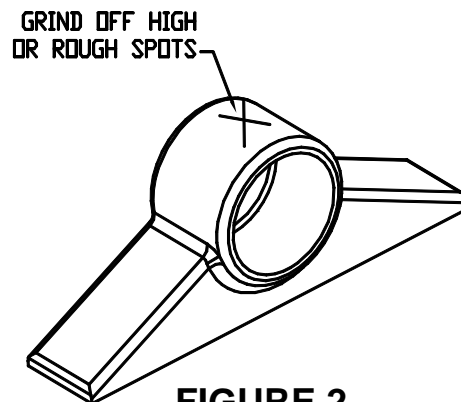

FIGURE 2

B. INSTALL JOST MODEL JSK 37F TOPPLATE (CONT.):

6. Using a suitable lifting device, lower the new Jost topplate onto the mounting bracket.
7. Install the pivot pins (item 3) aligning the flange with the threaded holes in the topplate casting.
8. Align a locking tab (item 2) with each pivot pin and install the ½-13 hex head cap screws (item 1) thru the locking tabs, the pivot pin flange and into the topplate casting ears.
9. Bend the locking tabs over each cap screw as shown in figure 5.

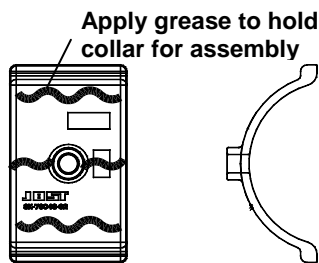

FIGURE 4

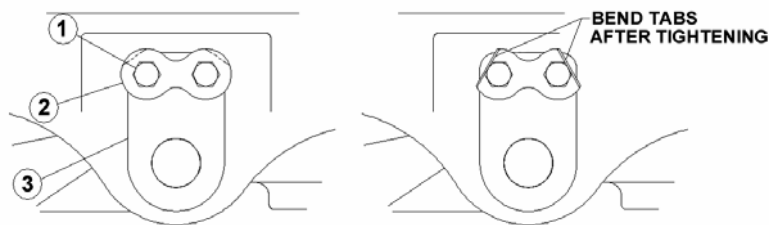

FIGURE 5

C. INSPECTION AND LUBRICATION PRIOR TO USE:

1. Review the installation. Be certain that all steps were completed properly.
2. Check the fifth wheel locking mechanism using a lock tester. It must lock and unlock as described in the Maintenance Procedures (LT SK37F-03). For additional copies of the Maintenance Procedures contact Jost.



CHECK THE LOCKING MECHANISM PRIOR TO USE. DO NOT USE ANY FIFTH WHEEL THAT FAILS TO OPERATE PROPERLY!

3. Apply grease to the top of the fifth wheel (where it contacts the trailer plate).