

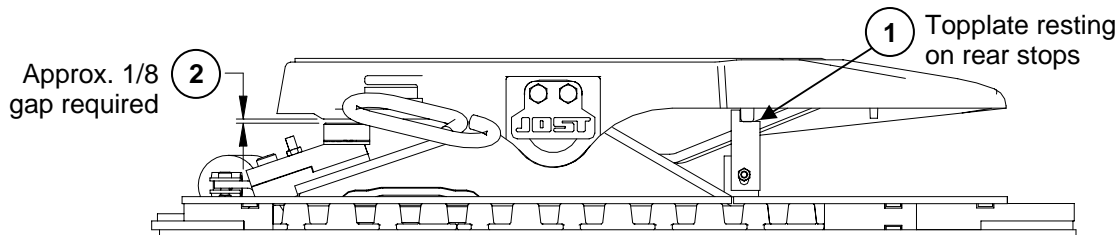

### **IMPORTANT**

### **SHIMMING INSTRUCTIONS FOR NO-TILT FIFTH WHEELS**

New No-Tilt assemblies come properly shimmed from the factory. Whenever a Topplate or No-Tilt Bracket is replaced in the field the front No-Tilt stops MUST be re-shimmed.

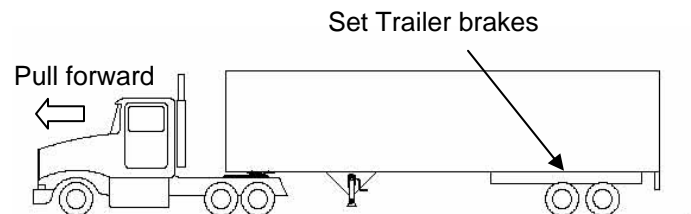

**FIGURE 1**

### **Shimming instructions**

#### **Step 1**

Be sure the rear tilt stops are engaged. Set the trailer brakes, pull forward and set the tractor brakes. This will rotate the topplate until it is resting on the rear stops (see Figure 1).



**FIGURE 2**

#### **Step 2**

Rotate the front stops in under the topplate. Now, slide the shims provided between the topplate skirt and the front stops (see Figure 3) to achieve an approximate 1/8-inch gap (see Figure 1). You may not need to use all the shims provided.

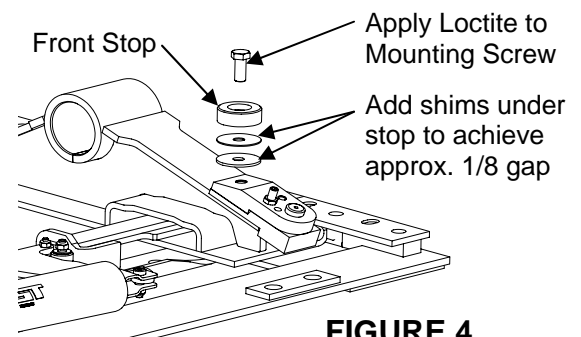

**FIGURE 3**

Note: The thickest shim is 1/8 inch thick and can be used to check the gap (see Figure 3).

#### **Step 3**

Remove each shim pack from step 2 above. Apply Loctite to the mounting screw.

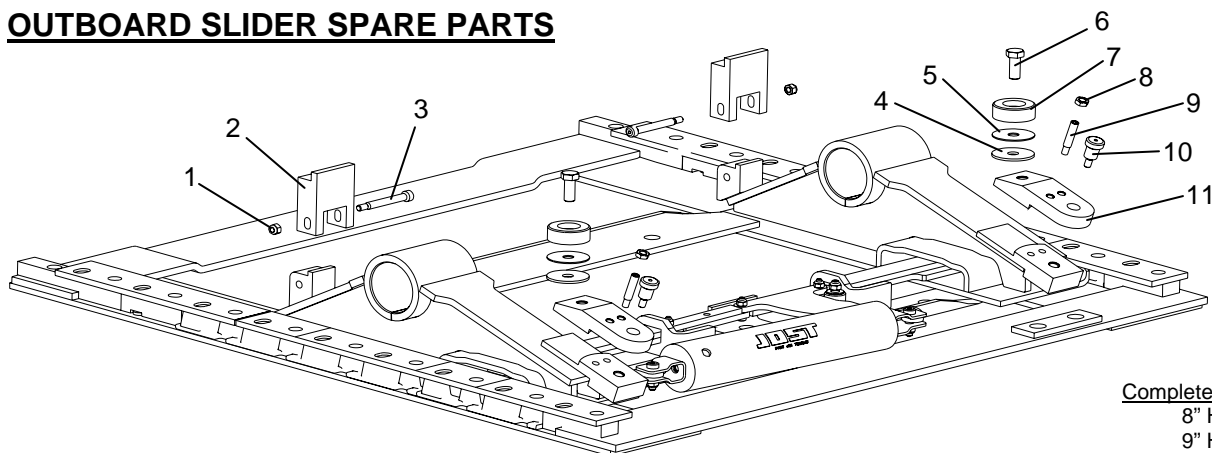

**FIGURE 4**

#### **Step 4**

Attach each front stop by installing the mounting screw through the front stop, the shim pack, and then into the front stop mount. Tighten each screw securely (see Figure 4).

## OUTBOARD SLIDER SPARE PARTS



Bracket Exchange  
8" High- NA8P  
9" High- NA9P

Complete Slide Bracket Assemblies  
8" High - SK-77083-08  
9" High - SK-77083-09

8" OUTBOARD SLIDER PARTS		
Item	Description	Part No.
1	Lock Nut	SK-70402-01
2	Rear Stop	SK-72066-01
3	3/8 Dia. x 2 1/2 lg. Shoulder Screw	SK-70201-02
4	Thick Shim (round)	SK-72068-12
5	Thin Shim (round)	SK-72068-06
6	1/2-13 Hex Head Screw	SK-70202-08
7	Front Stop	SK-72065-08
8	Jam Nut	SK-70403-04
9	Set Screw	SK-72070-00
10	5/8 Dia. x 3/4 lg. Shoulder Screw	SK-70201-14
11	Front Tilt Stop Plate	SK-77084-00

9" OUTBOARD SLIDER PARTS		
Item	Description	Part No.
1	Lock Nut	SK-70402-01
2	Rear Stop	SK-72066-02
3	3/8 Dia. x 2 1/2 lg. Shoulder Screw	SK-70201-02
4	Thick Shim (round)	SK-72068-12
5	Thin Shim (round)	SK-72068-06
6	1/2-13 Hex Head Screw	SK-70202-16
7	Front Stop	SK-72065-09
8	Jam Nut	SK-70403-04
9	Set Screw	SK-72070-00
10	5/8 Dia. x 3/4 lg. Shoulder Screw	SK-70201-14
11	Front Tilt Stop Plate	SK-77084-00

## STATIONARY SPARE PARTS

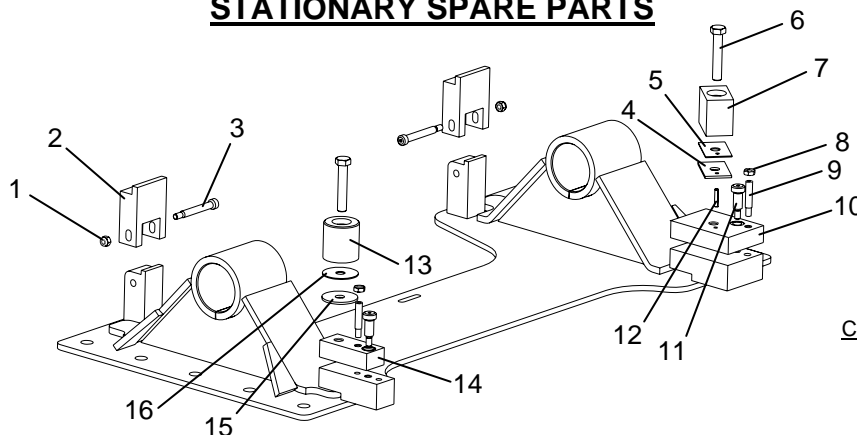

Complete Stationary Assemblies  
8" High - NDB8X  
9" High - NDB9X

8" STATIONARY PARTS		
Item	Description	Part No.
1	Lock Nut	SK-70402-01
2	Rear Stop	SK-72066-01
3	3/8 Dia. x 2 1/2 lg. Shoulder Screw	SK-70201-02
4	Thick Shim (rectangle)	SK-72069-12
5	Thin Shim (rectangle)	SK-72069-06
6	1/2-13 Hex Head Screw	SK-70202-17
7	L.H. Front Stop	SK-72067-08
8	Jam Nut	SK-70403-04
9	Set Screw	SK-72070-00
10	L.H. Front Tilt Stop Plate	SK-72064-00
11	1/2 Dia. x 1 lg. Shoulder Screw	SK-70201-12
12	Roll Pin	SK-70104-03
13	R.H. Front Stop	SK-72065-18
14	R.H. Front Tilt Stop Plate	SK-72063-00
15	Thick Shim (round)	SK-72068-12
16	Thin Shim (round)	SK-72068-06

9" STATIONARY PARTS		
Item	Description	Part No.
1	Lock Nut	SK-70402-01
2	Rear Stop	SK-72066-01
3	3/8 Dia. x 2 1/2 lg. Shoulder Screw	SK-70201-02
4	Thick Shim (rectangle)	SK-72069-12
5	Thin Shim (rectangle)	SK-72069-06
6	1/2-13 Hex Head Screw	SK-70202-18
7	L.H. Front Stop	SK-72067-09
8	Jam Nut	SK-70403-04
9	Set Screw	SK-72070-00
10	L.H. Front Tilt Stop Plate	SK-72064-00
11	1/2 Dia. x 1 lg. Shoulder Screw	SK-70201-12
12	Roll Pin	SK-70104-03
13	R.H. Front Stop	SK-72065-19
14	R.H. Front Tilt Stop Plate	SK-72063-00
15	Thick Shim (round)	SK-72068-12
16	Thin Shim (round)	SK-72068-06

## INBOARD SLIDER SPARE PARTS

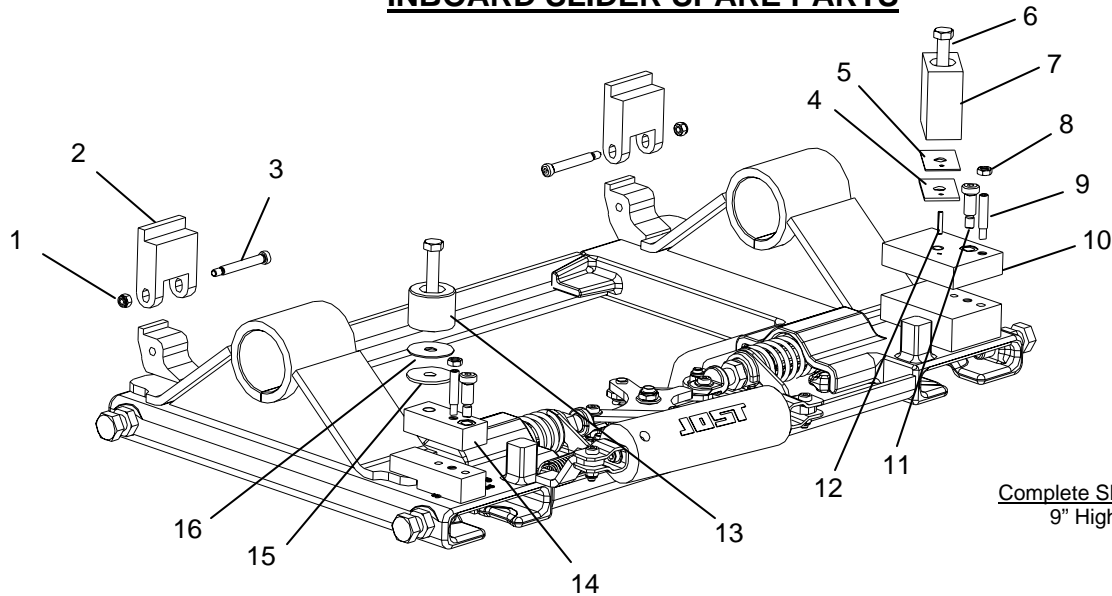

Bracket Exchange  
9" High- NB9P

Complete Slide Bracket Assembly  
9" High - SK-77203-09

<b>9" INBOARD SLIDER PARTS</b>		
<b>Item</b>	<b>Description</b>	<b>Part No.</b>
1	Lock Nut	SK-70402-01
2	Rear Stop	SK-72066-01
3	3/8 Dia. x 2 1/2 Ig. Shoulder Screw	SK-70201-02
4	Thick Shim (rectangle)	SK-72069-12
5	Thin Shim (rectangle)	SK-72069-06
6	1/2-13 Hex Head Screw	SK-70202-26
7	L.H. Front Stop	SK-72067-29
8	Jam Nut	SK-70403-04
9	Set Screw	SK-72070-00
10	L.H. Front Tilt Stop Plate	SK-72064-00
11	1/2 Dia. x 1 Ig. Shoulder Screw	SK-70201-12
12	Roll Pin	SK-70104-03
13	R.H. Front Stop	SK-72065-29
14	R.H. Front Tilt Stop Plate	SK-72063-00
15	Thick Shim (round)	SK-72068-12
16	Thin Shim (round)	SK-72068-06