

Your **JOST** fifth wheel has been designed and manufactured to provide years of trouble free service. These procedures cover only the fifth wheel operation. It is important to follow each step of these instructions.

Note: If possible keep the fifth wheel from extended sunlight exposure at elevated temperatures. This may cause the lube plates to expand and pucker between bolts. Some expansion is normal. The plates will flatten when the fifth wheel is coupled.

COUPLING PROCEDURES

A. INSPECT THE FIFTH WHEEL

1. The ramps must be tilted down (see figure 1).
2. The locks must be open.
3. Inspect the condition of the fifth wheel low lube pads. There should be no damaged or missing pieces. Slight puckering at the outside edges is normal.

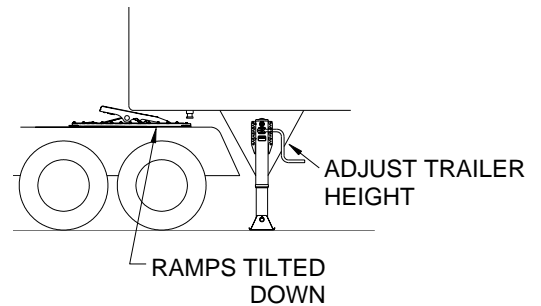

FIGURE 1

B. PREPARE THE TRAILER

1. Back up close to trailer centering kingpin on fifth wheel.
2. Block trailer wheels.
3. Connect air lines and light cord.
4. Set trailer brakes.
5. Adjust the trailer height.

IMPORTANT! The trailer should contact the fifth wheel at the pivot (see figure 1). When coupling, the fifth wheel must slide freely under the trailer. Do not lift the trailer with the fifth wheel, this will stretch the low lube plates.

When adjusting the trailer height do not lift the trailer too high. When coupling there should never be a gap between the trailer upper coupler and the fifth wheel.



**ATTEMPTING TO COUPLE AT THE WRONG HEIGHT
MAY CAUSE IMPROPER COUPLING, WHICH COULD
RESULT IN DAMAGE OR PERSONAL INJURY!**

C. COUPLE TRAILER

1. Back under trailer.
2. After sliding under the trailer, **STOP** (stopping prevents hitting the kingpin too hard).
3. Continue backing until fifth wheel locks.
4. Pull forward to test the coupling as an initial check.

 **A VISUAL INSPECTION IS REQUIRED BY LAW. SOME IMPROPER COUPLINGS CAN PASS A PULL TEST. SOUND IS NOT RELIABLE. GET OUT OF THE CAB AND LOOK.**

D. VISUAL INSPECTION

1. Check that there is **NO GAP** between the trailer bolster and the fifth wheel (see figure 2).
2. Check that the **KINGPIN** is **INSIDE** the **LOCK** (see figure 2).
3. Check that the retractable handle **LOCK NOTCH** is **INSIDE** the casting (see figure 3).

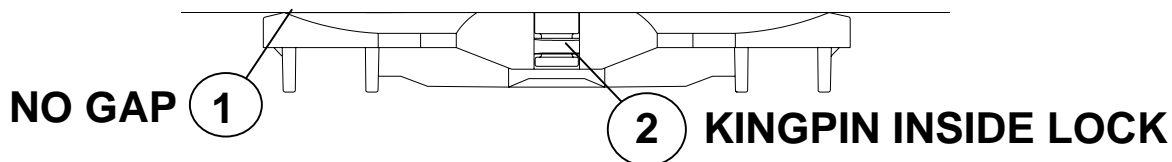

FIGURE 2

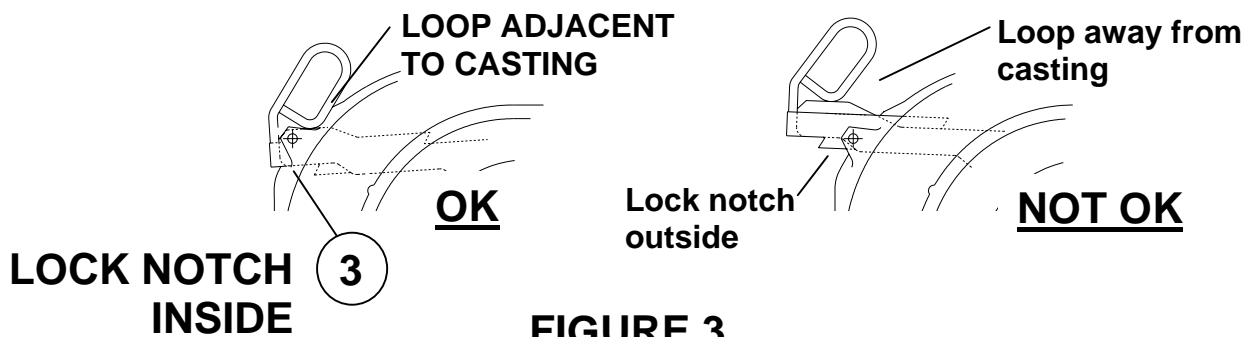

FIGURE 3

UNCOUPLING PROCEDURES

A. PREPARE FOR UNCOUPLING

1. Uncouple in a location that provides support for the landing gear.
2. Set trailer brakes.
3. Slowly back tightly against trailer and set tractor emergency brake.
4. Block trailer wheels.
5. Lower trailer landing gear until they touch the ground. Shift to low gear and crank a few extra turns.
6. Disconnect the brake lines and light cord.

B. UNCOUPLING

1. Unlock the fifth wheel:
Pull the retractable handle out. Hook handle in open position using notch (see figure 4).
2. Release the tractor emergency brake and pull out slowly allowing the trailer to slide down the fifth wheel and pick up ramps.

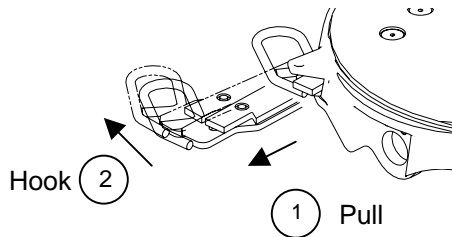

FIGURE 4

SLIDING FIFTH WHEEL – SLIDING PROCEDURE

A. PREPARE FOR SLIDING

1. Stop vehicle in a straight line on level ground.
2. Set the trailer brakes.
3. Disengage the locking plungers as shown in figure 5.

B. SLIDE TO DESIRED POSITION

1. Check that both plungers have retracted.
2. Release the tractor brakes.
3. Drive the tractor to the desired position.

C. ENGAGE LOCKING PLUNGERS

1. Engage the locking plungers as shown in figure 5.
2. Visually check that both plungers engaged.
3. It may be necessary to move tractor slightly to allow plungers to engage.

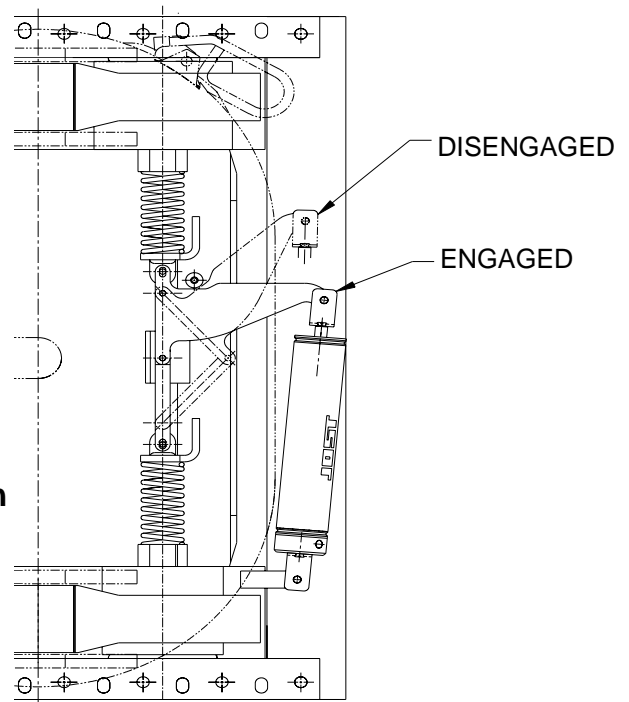

FIGURE 5

WARNING DO NOT OPERATE THE VEHICLE IF THE PLUNGERS ARE NOT FULLY ENGAGED – PERSONAL INJURY OR DAMAGE TO THE TRACTOR OR TRAILER MAY OCCUR.