

The first environmentally safe landing gear



## A440 MAGNUM

Requires no lubrication for five years!!!

Maximum Static Load Rating:  
\*200,000 lbs.

Rated Lift Capacity:  
62,500 lbs.  
w/100ft-lbs input torque

Side Load Capacity:  
\*33,000 lbs. per set



The gear box is completely filled with an arctic grade, all weather white grease.

The legs are completely sealed to keep water out.

Seals are used to keep water from rotating shafts.

The elevating screws are completely encased by a grease tube.

Each time the legs are extended and retracted, the screws will receive a fresh coating of grease.

Gear Ratio:  
Low: 32 turns = 1" travel  
High: 3.5 turns = 1" travel

Specify the A440 Magnum and forget your landing gear for five years.

*The reasons are simple*



See reverse side for order information

\*When properly braced on a trailer.

# MAGNUM LANDING GEAR

www.jostinternational.com

A440R T1 17 38

Landing Gear Product Line Prefix

Mounting Style

Leg Speed

Footwear

Travel

Options

A44

14 - 14" Travel  
17 - 17" Travel  
19 - 19" Travel

05 - Removable crank  
38 - Removable cushion foot for G or G3

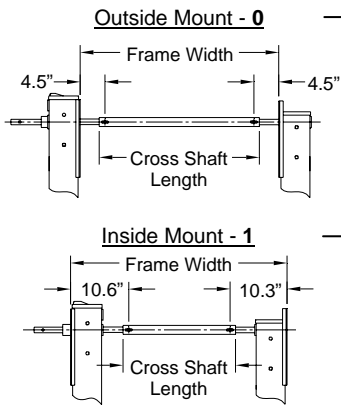

†Leave Blank for Both Legs  
R.H. Two Speed Leg - R  
L.H. One Speed Leg - L

† When ordering both legs; crank, crank hanger, brace lugs and a cross shaft are included but need to be specified (see below).

"G" Series - Cushion Foot

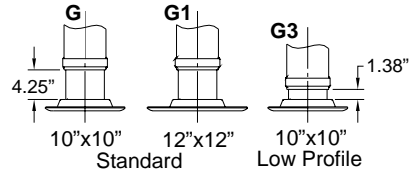

"T" Series - Sand Shoe

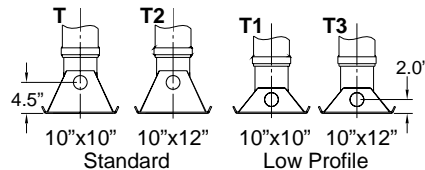

## Cross Shaft

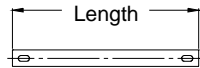

B10363.59.4

Inside Mount - B10363  
Outside Mount - B10066

Length (in)  
Standard Inside Mount= 56.5"  
Standard Outside Mount= 68.4"  
(If other length is desired see note).

Inside Mount Example: 78.9" - 19.5" = 59.4"  
Frame Width = 78.9" Overall Length = 59.4"

Note:  
Cross Shaft Length =  
Frame width - 19.5" (for Inside mount)  
- 7.6" (for outside mount)

## Travel Dimensions

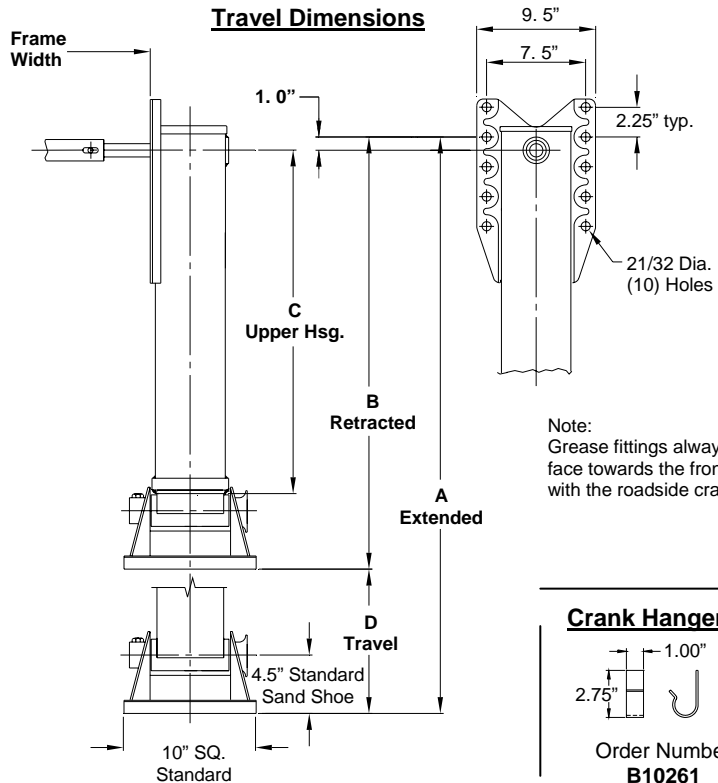

## Crank

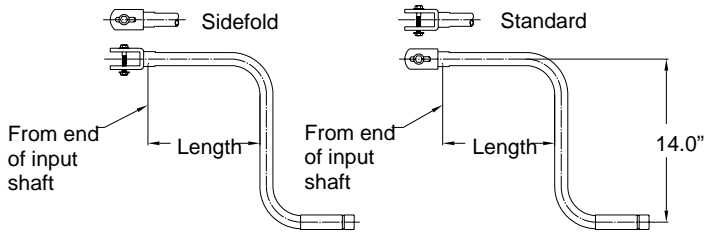

C10592.1

Standard - C10592  
Sidefold - C10591

Length  
1 - 5 1/4"  
2 - 8 1/4" (Standard)  
3 - 10 1/2"  
4 - 17 3/4"  
5 - 14 3/4"

| D Travel | Standard Footwear |              | Low Profile (Sand Shoe) |              | Low Profile (Cushion Foot) |              | C Upper Hsg. |
|----------|-------------------|--------------|-------------------------|--------------|----------------------------|--------------|--------------|
|          | A1-Extended       | B1-Retracted | A2-Extended             | B2-Retracted | A3-Extended                | B3-Retracted |              |
| 14"      | 42 5/8"           | 28 5/8"      | 40 1/8"                 | 26 1/8"      | 39 3/4"                    | 25 3/4"      | 21 15/16"    |
| 17"      | 48 5/8"           | 31 5/8"      | 46 1/8"                 | 29 1/8"      | 45 3/4"                    | 28 3/4"      | 24 15/16"    |
| 19"      | 52 5/8"           | 33 5/8"      | 50 1/8"                 | 31 1/8"      | 49 3/4"                    | 30 3/4"      | 26 15/16"    |

The right to alter specifications is reserved.



1770 Hayes Street  
Grand Haven, MI 49417  
www.jostinternational.com

Ph. (616) 846-7700 (800) 253-5105  
Fax (616) 846-0310

LT LG440-01 RevE